



IDC255

ICE DRINK DISPENSER



Unit shown with UFB-1™ sanitary lever valves. Available with 8 or 10 valve configuration

FEATURES

Quality - Delivers bottle-quality drinks every time with built-in cold carbonator

Intellcarb™ - Meets IntelliCarb™ specification

Merchandising - Creates high-impact marketing messages delivered with easily modified illuminated merchandiser

Intelligent - Automatically separates ice dispensed into cups from ice used to cool cold plate

Accommodating - Reduces ice spillage with increased drip tray capacity

Flexibility - Dispenses different ice types thanks to the contour of the hopper and geometry of the beverage dispenser

Ice system - Readily accepts top-mounted ice makers with manual ice-fill capability

TotalFlex™ manifold - easily changes from carbonated to non-carbonated

Easy to use - Requires only one electrical outlet

- Easy front access to carbonator tank
- Simple motor removal



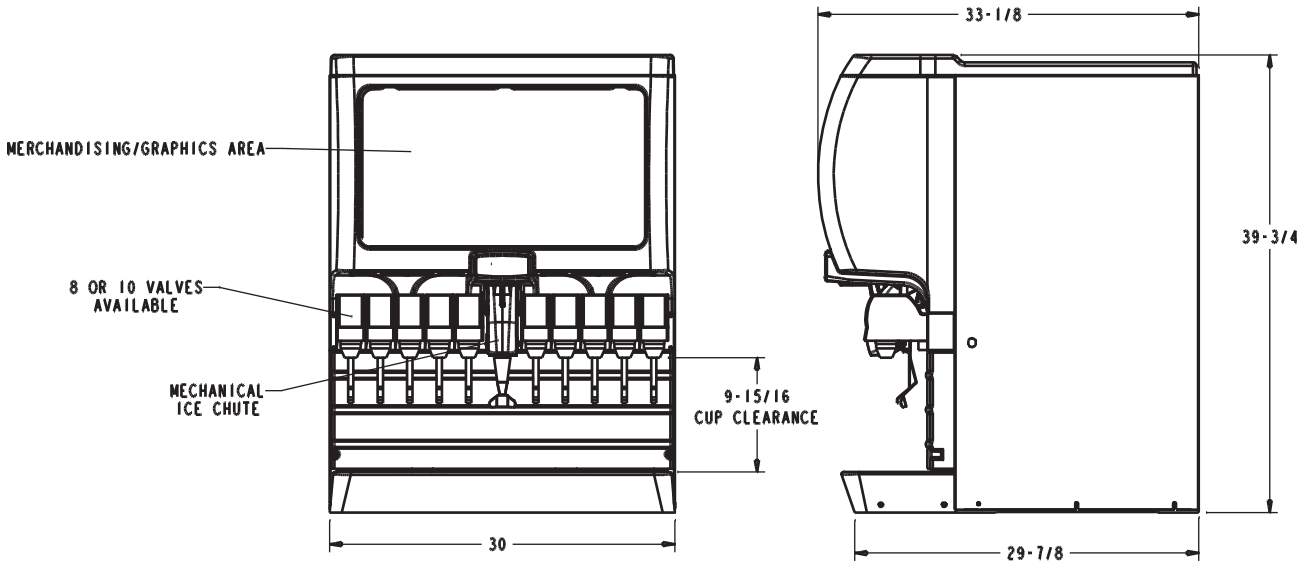

NOTE: PUMP & MOTOR ASSEMBLY
MUST BE POSITIONED WITHIN
8 FEET OF THE DISPENSER

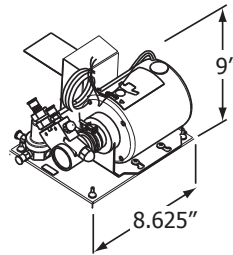

| PART NUMBER | DESCRIPTION |
|-------------|---|
| 621057405 | IDC255 with 8 UFB-1™ 2-4 oz Sanitary Lever valves, 115 V / 60 Hz |
| 621057403 | IDC255 with 8 UFB-1™ 2-4 oz Push Button valves, 115 V / 60 Hz |
| 621057407 | IDC255 with 10 UFB-1™ 2-4 oz Sanitary Lever valves, 115 V / 60 Hz |
| 621057406 | IDC255 with 10 UFB-1™ 2-4 oz Push Button valves, 115 V / 60 Hz |

TECHNICAL SPECIFICATIONS

| | | | |
|--------------------------------|--|-----------------------------|--|
| TYPE OF VALVES | UFB-1™ 2-4 oz / sec post-mix | DRAIN SIZE | 0.75" (19.1 mm) pvc (npt) pipe or flexible tubing |
| NUMBER OF VALVES | 8 or 10 | ELECTRICAL REQUIREMENTS . . | 115 V / 60 Hz / 9.3 Amps or 230 V / 50/60 HZ / 4.7 Amps |
| BEVERAGE MANIFOLDING | TotalFlex™ | SHIPPING WEIGHT | 350 lb (150 kg) |
| CUP CLEARANCE | 10" | AGENCY LISTINGS |    City of Los Angeles |
| GRAPHIC DIMENSIONS | (Template Available) | | |
| ICE STORAGE CAPACITY | 255 lb (115.7 kg) | | |
| CONNECTIONS | Water: 0.375" (9.5 mm) Syrup: 0.375" (9.5 mm) | | |
| STANDARD FEATURES | Timed ice agitation, key switch and 4" legs | | |

Pepsi is a registered trademark of Pepsi Co, Inc.



© 2014 CORNELIUS

CP5009-0714

IN THE U.S.A.
Ph: 800.238.3600
Fax: 800.258.0255

OUTSIDE THE U.S.A.
Ph: 763.488.8200
Email: webmaster@cornelius.com

101 Broadway Street West
Osseo, MN 55369
www.cornelius.com

For more information or to place an order, contact your sales representative or authorized distributor.